

GENERAL PURPOSE APPLICATION.  
SWITCHING APPLICATION.

#### FEATURES

- Low Leakage Current  
:  $I_{CEX} = -50\text{nA}(\text{Max.})$ ;  $V_{CE} = -30\text{V}$ ,  $V_{EB} = -0.5\text{V}$ .
- Low Saturation Voltage  
:  $V_{CE(\text{sat})} = -0.4\text{V}(\text{Max.})$ ;  $I_C = -150\text{mA}$ ,  $I_B = -15\text{mA}$ .
- Complementary to the KN2222/2222A.

#### MAXIMUM RATING (Ta=25 °C)

CHARACTERISTIC	SYMBOL	RATING		UNIT
		KN2907	KN2907A	
Collector-Base Voltage	$V_{CBO}$	-60		V
Collector-Emitter Voltage	$V_{CEO}$	-40	-60	V
Emitter-Base Voltage	$V_{EBO}$	-5		V
Collector Current	$I_C$	-600		mA
Collector Power Dissipation	$P_C$	625		mW
Junction Temperature	$T_j$	150		°C
Storage Temperature Range	$T_{\text{stg}}$	-55 ~ 150		°C

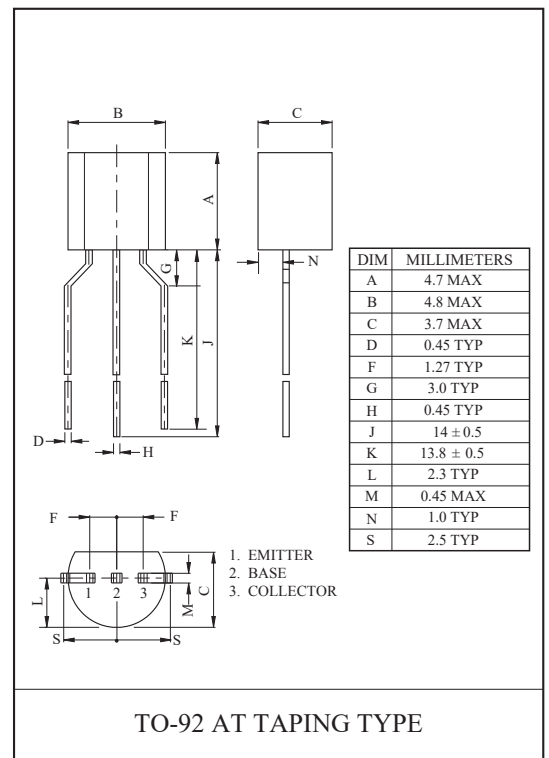
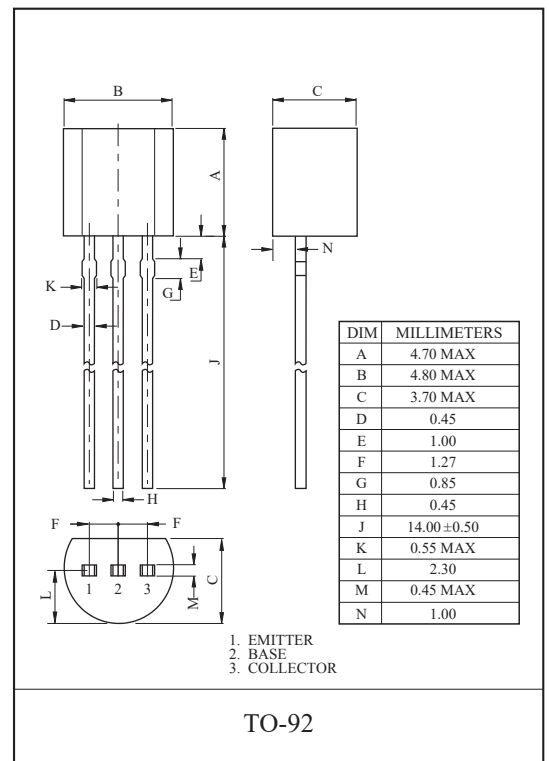

# KN2907/A

## ELECTRICAL CHARACTERISTICS (Ta=25 °C)

CHARACTERISTIC		SYMBOL	TEST CONDITION	MIN.	TYP.	MAX.	UNIT
Collector Cut-off Current		$I_{CEX}$	$V_{CE}=-30V, V_{EB}=-0.5V$	-	-	-50	nA
Collector Cut-off Current	KN2907	$I_{CBO}$	$V_{CB}=-50V, I_E=0$	-	-	-20	nA
	KN2907A			-	-	-10	
Collector-Base Breakdown Voltage		$V_{(BR)CBO}$	$I_C=-10\mu A, I_E=0$	-60	-	-	V
Collector-Emitter Breakdown Voltage *	KN2907	$V_{(BR)CEO}$	$I_C=-10mA, I_B=0$	-40	-	-	V
	KN2907A			-60	-	-	
Emitter-Base Breakdown Voltage		$V_{(BR)EBO}$	$I_E=-10\mu A, I_C=0$	-5	-	-	V
DC Current Gain	KN2907	$h_{FE(1)}$	$I_C=-0.1mA, V_{CE}=-10V$	35	-	-	
	KN2907A			75	-	-	
	KN2907	$h_{FE(2)}$	$I_C=-1.0mA, V_{CE}=-10V$	50	-	-	
	KN2907A			100	-	-	
	KN2907	$h_{FE(3)}$	$I_C=-10mA, V_{CE}=-10V$	75	-	-	
	KN2907A			100	-	-	
	KN2907	$h_{FE(4)} *$	$I_C=-150mA, V_{CE}=-10V$	100	-	300	
	KN2907A						
KN2907	$h_{FE(5)} *$	$I_C=-500mA, V_{CE}=-10V$	30	-	-		
KN2907A			50	-	-		
Collector-Emitter Saturation Voltage *		$V_{CE(sat)1}$	$I_C=-150mA, I_B=-15mA$	-	-	-0.4	V
		$V_{CE(sat)2}$	$I_C=-500mA, I_B=-50mA$	-	-	-1.6	
Base-Emitter Saturation Voltage *		$V_{BE(sat)1}$	$I_C=-150mA, I_B=-15mA$	-	-	-1.3	V
		$V_{BE(sat)2}$	$I_C=-500mA, I_B=-50mA$	-	-	-2.6	
Transition Frequency		$f_T$	$V_{CE}=-20V, I_C=-50mA, f=100MHz$	200	-	-	MHz
Collector Output Capacitance		$C_{ob}$	$V_{CB}=-10V, I_E=0, f=1MHz$	-	-	8	pF

\* Pulse Test : Pulse Width  $\leq 300\mu s$ , Duty Cycle  $\leq 2\%$ .

# KN2907/A

$h_{FE} - I_C$

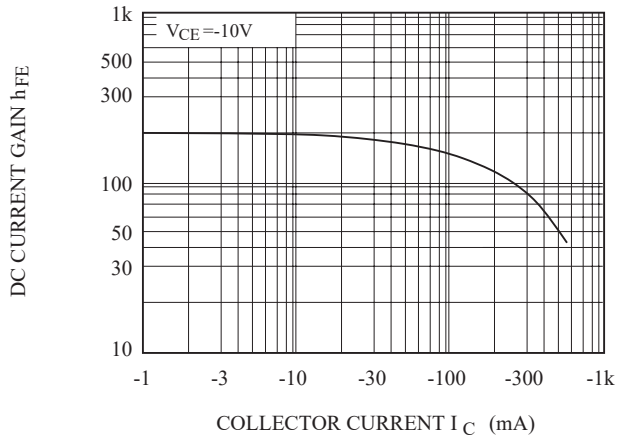

$C_{ob} - V_{CB}$

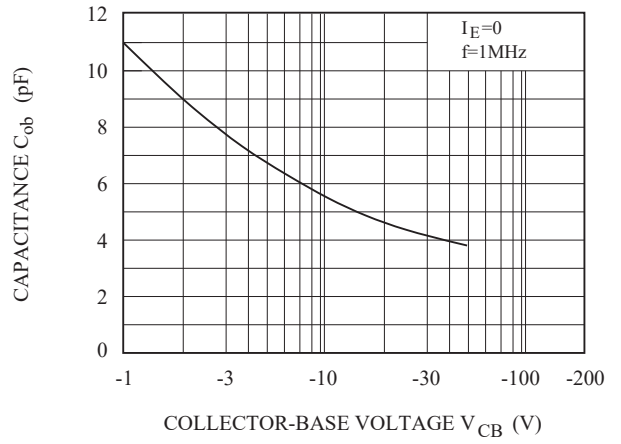

$V_{BE(sat)}, V_{CE(sat)} - I_C$

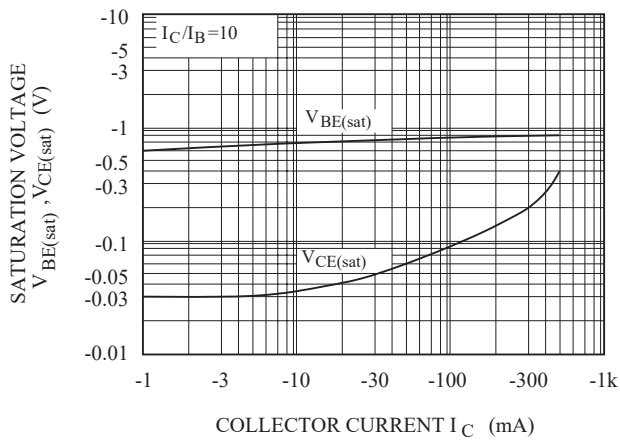

$P_c - T_a$

