

2A ADJUSTABLE LOW DROP VOLTAGE REGULATOR

The KIA278R00PI is a Low Drop Voltage Regulator suitable for various electronic equipments. It provides constant voltage power source with TO-220-4 terminal lead full molded PKG. The Regulator has multi function such as over current protection, overheat protection.

FEATURES

- Adjustable Output Voltage (Range : 1.5~30V)
- 2.0A Output Low Drop Voltage Regulator.
- Built in Over Current Protection, Over Heat Protection Function.
- Suffix U : Qualified to AEC-Q101.
ex) KIA278R00PI-U/PU

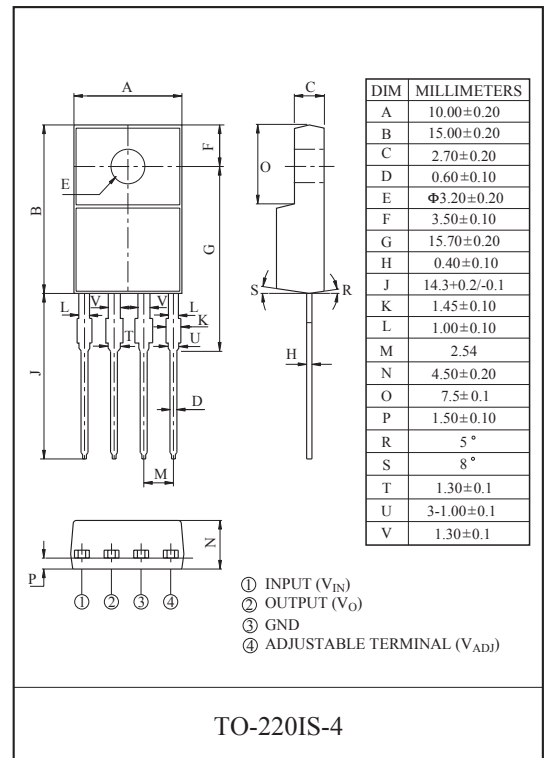

MAXIMUM RATINGS (Ta=25°C)

CHARACTERISTIC	SYMBOL	RATING	UNIT	Remark
Input Voltage	V_{IN}	35	V	-
Output Current	I_{OUT}	2	A	-
Power Dissipation 1	P_{D1}	1.5	W	No heatsink
Power Dissipation 2	P_{D2}	15	W	with heatsink
Operating Junction Temperature	$T_{J(opr)}$	-40~150	°C	-
Storage Temperature	T_{stg}	-45 ~ 150	°C	-
Soldering Temperature (10sec)	T_{sol}	260	°C	-

KIA278R00PI

ELECTRICAL CHARACTERISTICS

(Unless otherwise specified, $V_{IN}=15V$, $V_O=10V$, $I_O=1A$, $R_1=390\Omega$ (Note1 : $V_{IN}=0.95V_{out}$))

CHARACTERISTIC	SYMBOL	CONDITIONS	MIN.	TYP.	MAX.	UNIT	
Input Voltage	V_{IN}	-	4.5	-	35	V	
Output Voltage	V_O	$R_2=63\Omega$ to $8.7k\Omega$	1.5	-	30	V	
Load Regulation	Reg Load	$I_O=5mA \sim 2A$	-	-	2.0	%	
Line Regulation	Reg Line	$V_{IN}=11V \sim 28V$	-	-	2.5	%	
Ripple Rejection	$R \cdot R$	$C_{ref}=0$	Refer to Fig.2	45	55	-	dB
		$C_{ref}=3.3\mu F$		55	65	-	
Reference Voltage	V_{ref}	-	1.26	1.29	1.32	V	
Temperature coefficient of reference Voltage	$T_C V_{ref}$	$T_j=0 \sim 125^\circ C$	-	± 1.0	-	%	
DropOut Voltage	V_D	$I_O=2A$ (Note1)	-	-	0.5	V	
Quiescent Current	I_Q	$I_O=0A$	-	-	10	mA	

BLOCK DIAGRAM

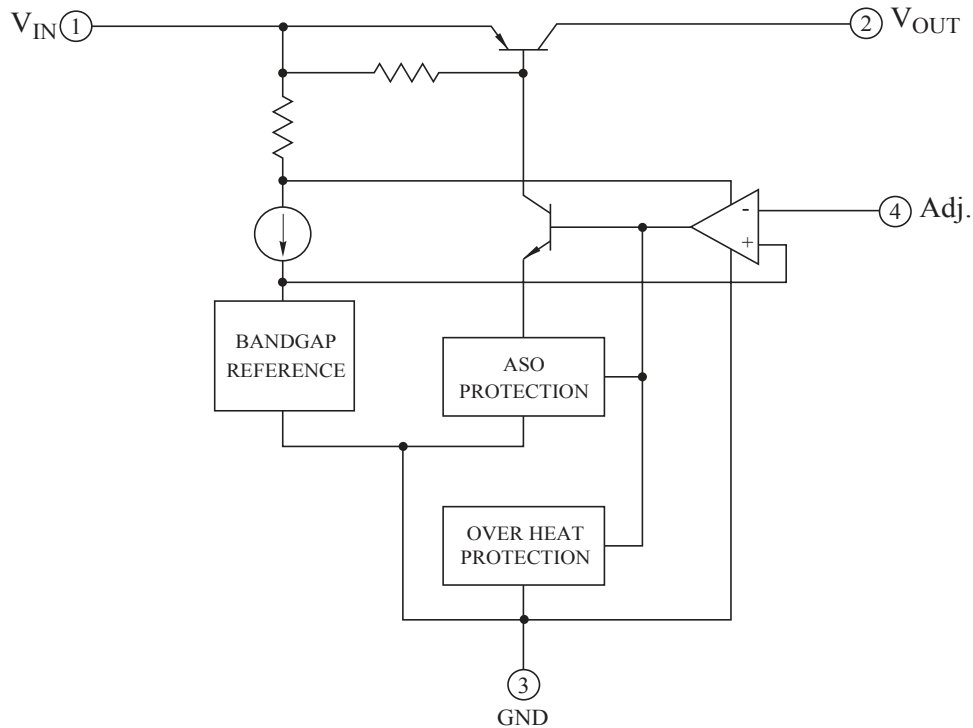

KIA278R00PI

Fig. 1 Standard Test Circuit

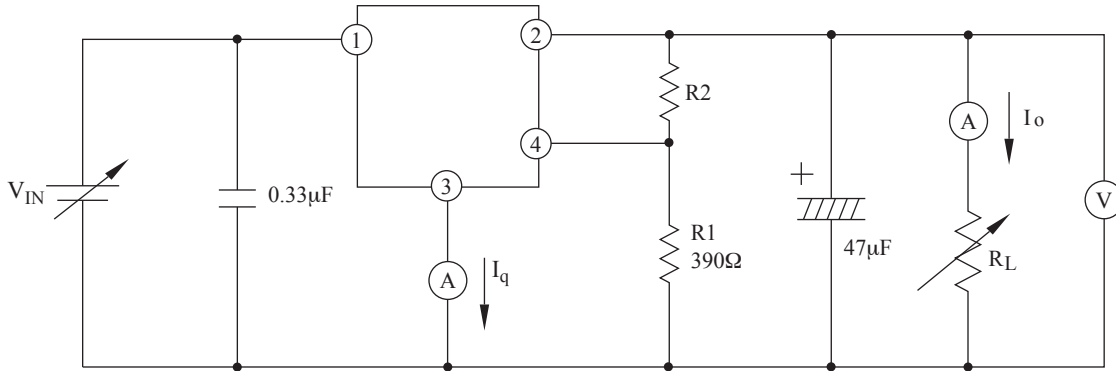

$$V_{OUT} = V_{ref} \times \left(1 + \frac{R2}{R1}\right) = 1.29 \times \left(1 + \frac{R2}{R1}\right)$$

Fig. 2 Ripple Rejection Circuit

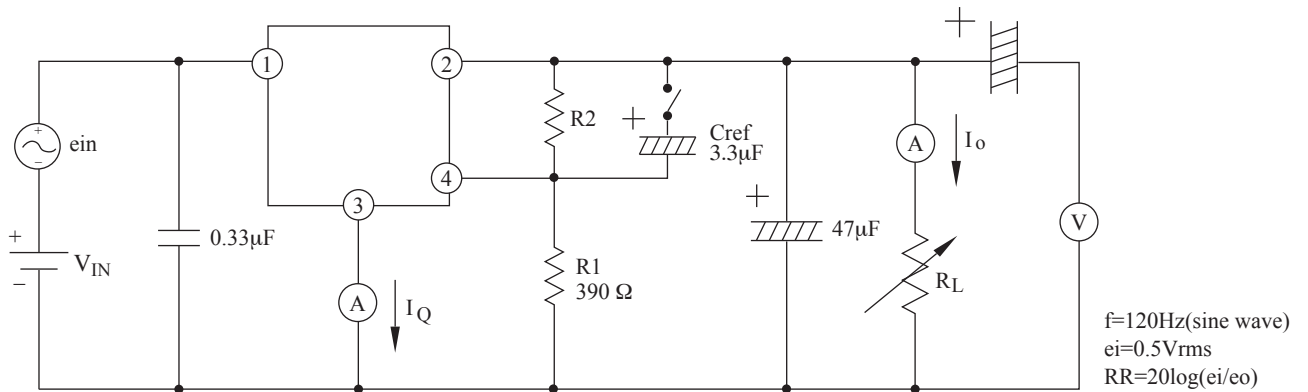

KIA278R00PI

Fig. 3 $T_a - P_D$

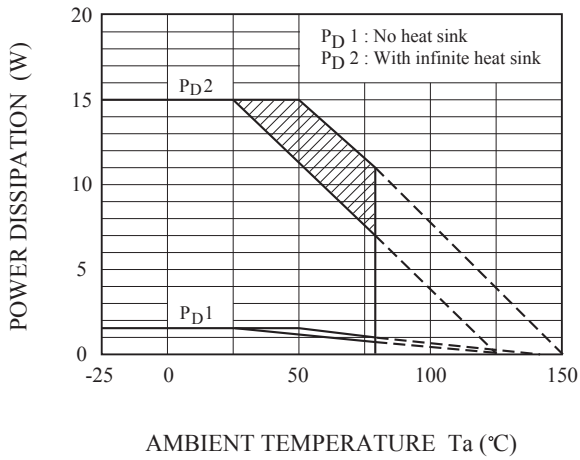

AMBIENT TEMPERATURE T_a (°C)
 Note) Oblique line portion : Overheat protection may operate in this area.

Fig. 4 $I_O - V_O$

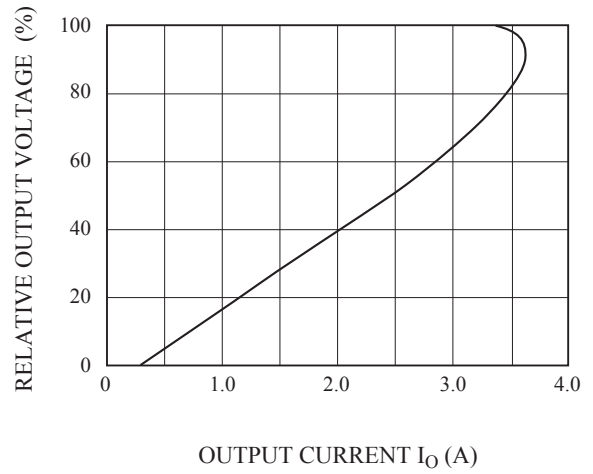

OUTPUT CURRENT I_O (A)

Fig. 5 $T_j - \Delta V_O$

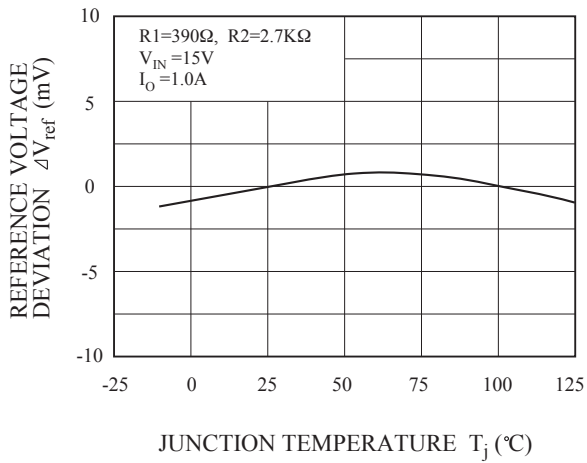

JUNCTION TEMPERATURE T_j (°C)

Fig. 6 $V_{IN} - V_{OUT}$

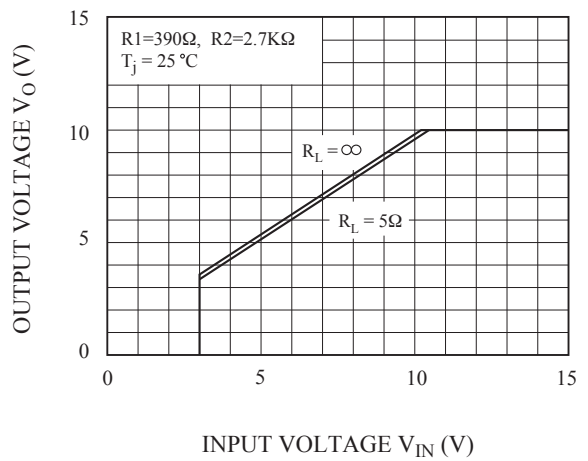

INPUT VOLTAGE V_{IN} (V)

Fig. 7 $T_j - V_D$

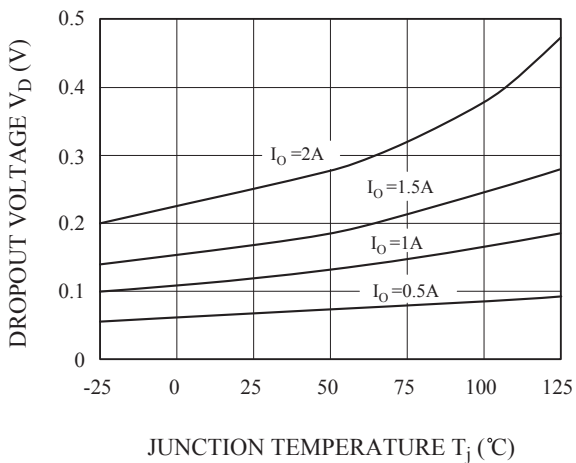

JUNCTION TEMPERATURE T_j (°C)

Fig. 8 $T_j - I_q$

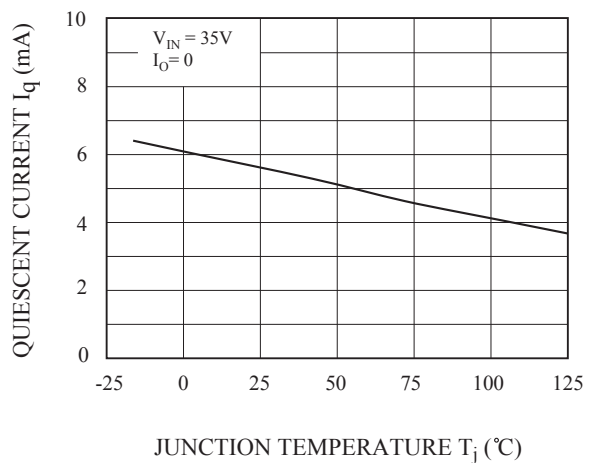

JUNCTION TEMPERATURE T_j (°C)

KIA278R00PI

Fig. 9 f - RR

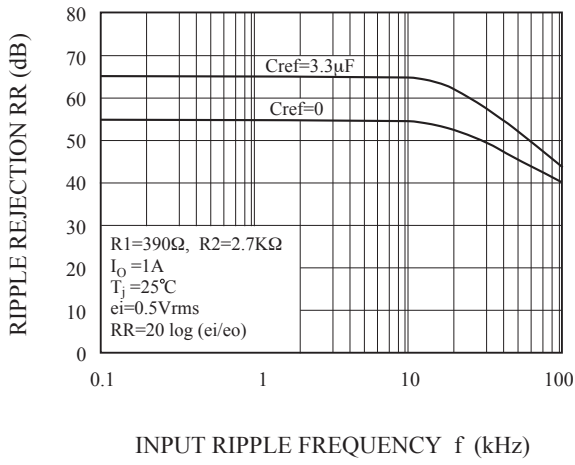

Fig. 10 I_O - RR

