

LMBT4403LT1G

S-LMBT4403LT1G

General Purpose Transistors PNP Silicon

1. FEATURES

- We declare that the material of product compliance with RoHS requirements and Halogen Free.
- S- prefix for automotive and other applications requiring unique site and control change requirements; AEC-Q101 qualified and PPAP capable.

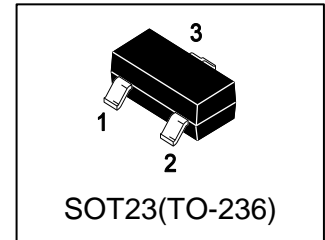

2. DEVICE MARKING AND ORDERING INFORMATION

Device	Marking	Shipping
LMBT4403LT1G	2T	3000/Tape&Reel
LMBT4403LT3G	2T	10000/Tape&Reel

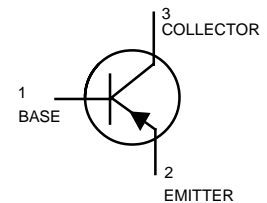

3. MAXIMUM RATINGS(Ta = 25°C)

Parameter	Symbol	Limits	Unit
Collector–Emitter Voltage	V _{CEO}	-40	V
Collector–Base Voltage	V _{CBO}	-40	V
Emitter–Base Voltage	V _{EBO}	-5	V
Collector Current — Continuous	I _C	-600	mA

4. THERMAL CHARACTERISTICS

Parameter	Symbol	Limits	Unit
Total Device Dissipation, FR-5 Board (Note 1) @ TA = 25°C Derate above 25°C	PD	225 1.8	mW mW/°C
Thermal Resistance, Junction–to–Ambient(Note 1)	R _{θJA}	556	°C/W
Total Device Dissipation, Alumina Substrate(Note 2) @ TA = 25°C Derate above 25°C	PD	300 2.4	mW mW/°C
Thermal Resistance, Junction–to–Ambient(Note 2)	R _{θJA}	417	°C/W
Junction and Storage temperature	T _J , T _{stg}	-55~+150	°C

1. FR-5 = 1.0×0.75×0.062 in.

2. Alumina = 0.4 x 0.3 x 0.024 in. 99.5% alumina.

5. ELECTRICAL CHARACTERISTICS (Ta= 25°C)
OFF CHARACTERISTICS

Characteristic	Symbol	Min.	Typ.	Max.	Unit
Collector–Emitter Breakdown Voltage (IC = -1.0 mA, IB = 0)	VBR(CEO)	-40	-	-	V
Collector–Base Breakdown Voltage (IC = -0.1 mA, IE = 0)	VBR(CBO)	-40	-	-	V
Emitter–Base Breakdown Voltage (IE = -0.1 mA, IC = 0)	VBR(EBO)	-5	-	-	V
Base Cutoff Current (VCE = -35 V, VEB = -0.4V)	IBEV	-	-	-0.1	μA
Collector Cutoff Current (VCE = -35 V, VEB = -0.4V)	ICEX	-	-	-0.1	μA

ON CHARACTERISTICS

DC Current Gain (IC = -0.1 mA, VCE = -1.0 V) (IC = -1.0 mA, VCE = -1.0 V) (IC = -10 mA, VCE = -1.0 V) (IC = -150 mA, VCE = -2.0 V) (IC = -500 mA, VCE = -2.0 V)	hFE	30 60 100 100 20	- - - - -	- - - 300 -	
Collector–Emitter Saturation Voltage (IC = -150 mA, IB = -15 mA) (IC = -500 mA, IB = -50 mA)	VCE(sat)	- -	- -	-0.4 -0.75	V
Base–Emitter Saturation Voltage (IC = -150 mA, IB = -15 mA) (IC = -500 mA, IB = -50 mA)	VBE(sat)	-0.75 -	- -	-0.95 -1.3	V

SMALL–SIGNAL CHARACTERISTICS

Current–Gain — Bandwidth Product (IC = -20mA, VCE = -10 V, f = 100 MHz)	fT	200	-	-	MHz
Collector–Base Capacitance (VCB = -10 V, IE = 0, f = 1.0 MHz)	Ccb	-	-	8.5	pF
Emitter–Base Capacitance (VBE = -0.5 V, IC = 0, f = 1.0 MHz)	Ceb	-	-	30	pF
Small–Signal Current Gain (VCE = -10 V, IC = -1.0 mA, f = 1.0 kHz)	hfe	60	-	500	-

SWITCHING CHARACTERISTICS

Delay Time	(VCC = -30V, VEB = -2.0V , IC = -150mA, IB1 = -15mA)	td	-	-	15	ns
Rise Time		tr	-	-	20	
Storage Time		ts	-	-	225	
Fall Time		tf	-	-	30	

 3. Pulse Test: Pulse Width $\leq 300 \mu\text{s}$, Duty Cycle $\leq 2.0\%$.

6.ELECTRICAL CHARACTERISTICS CURVES

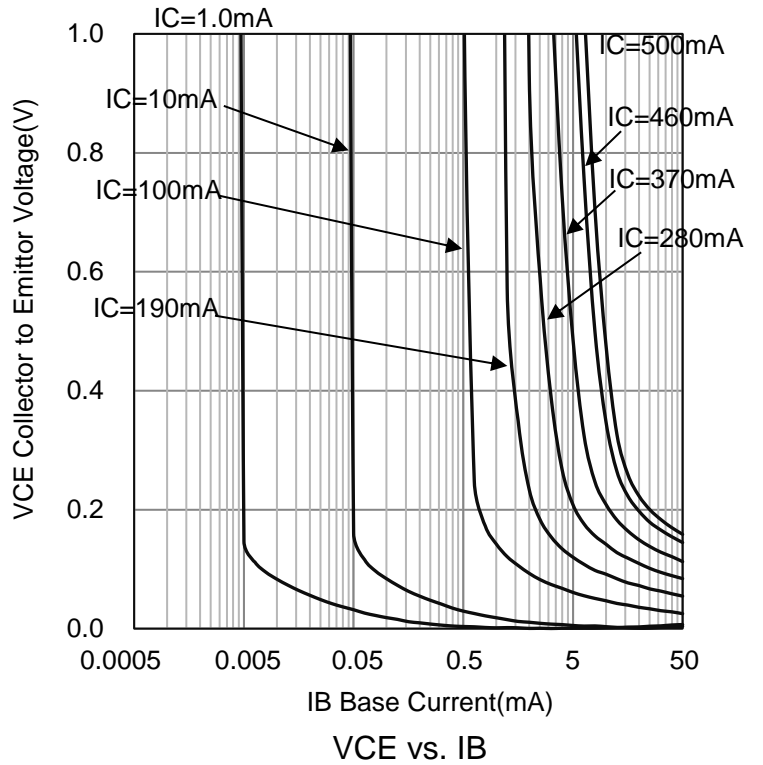
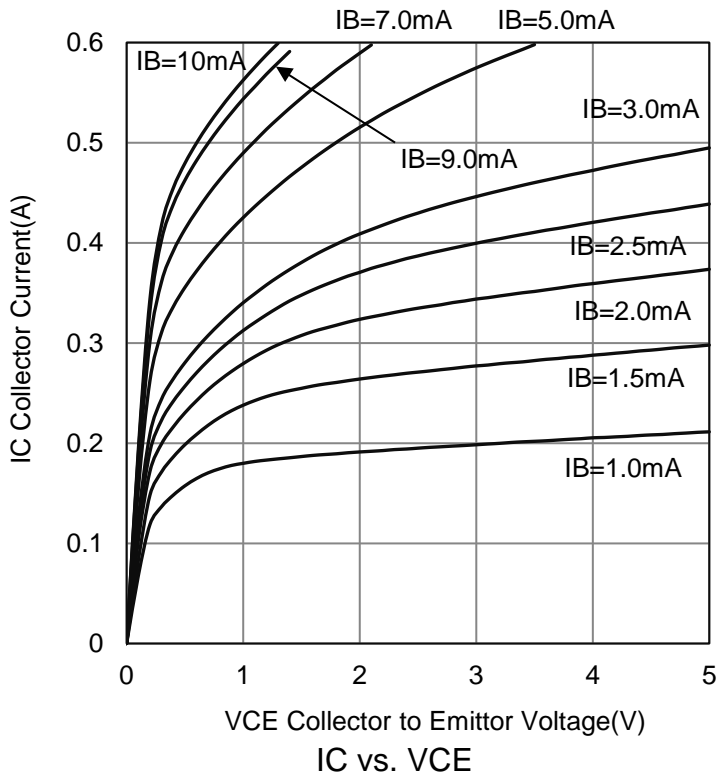
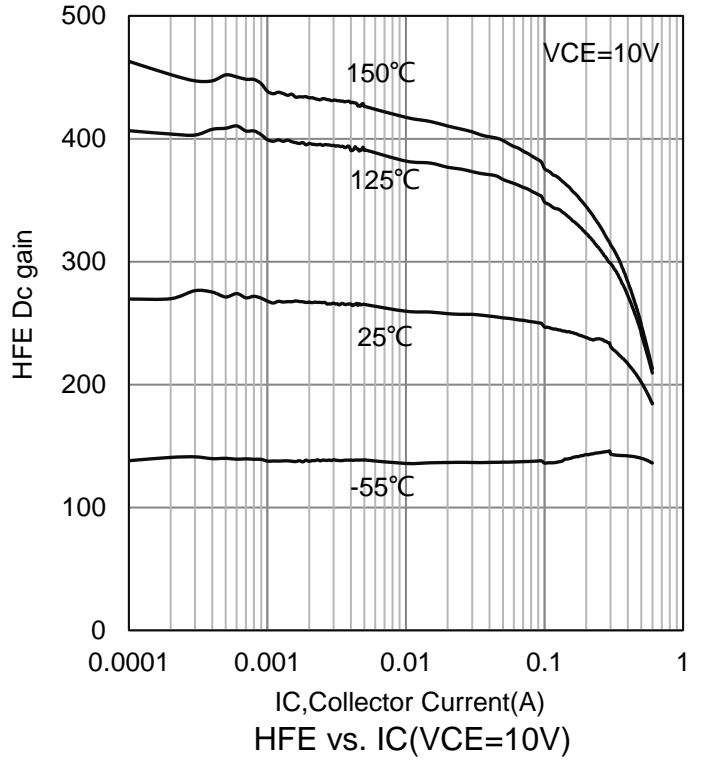
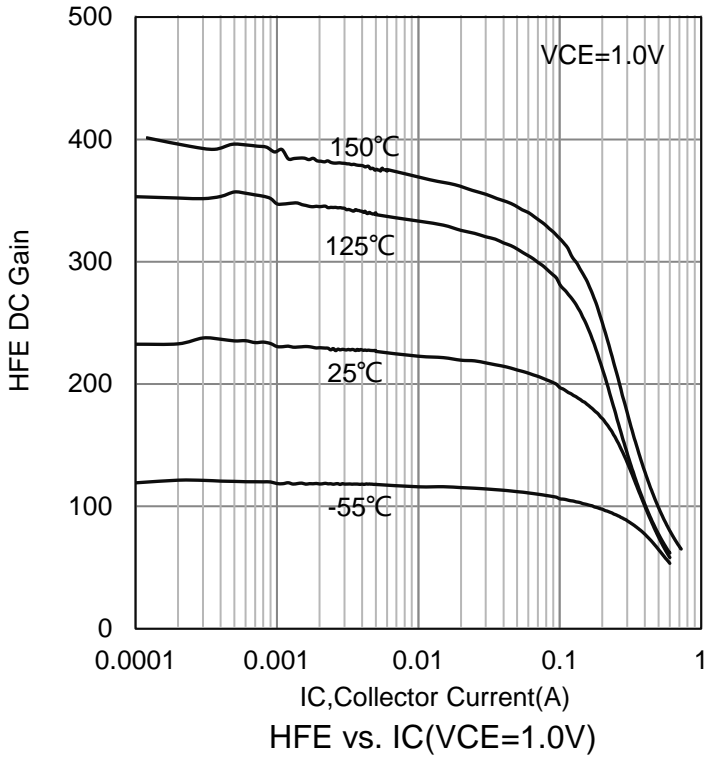

6.ELECTRICAL CHARACTERISTICS CURVES(Con.)

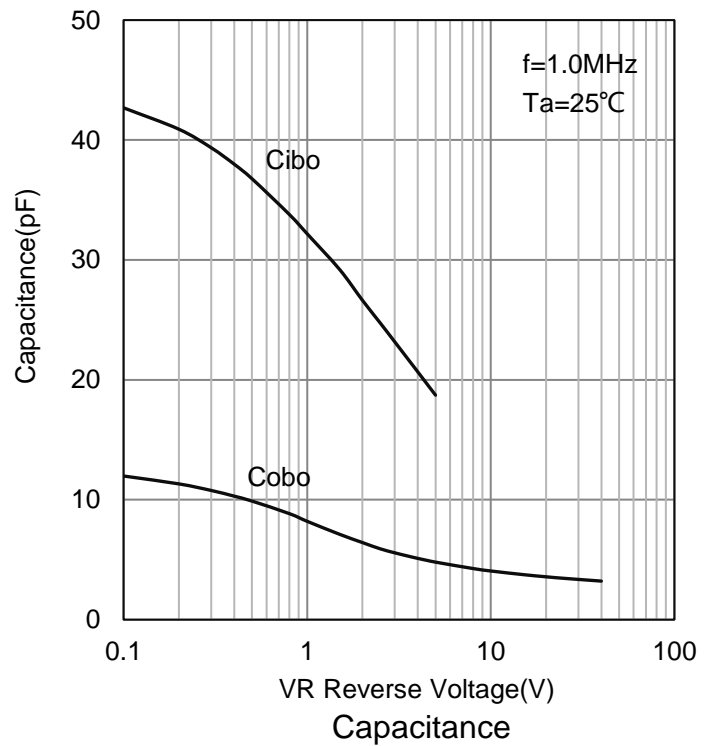
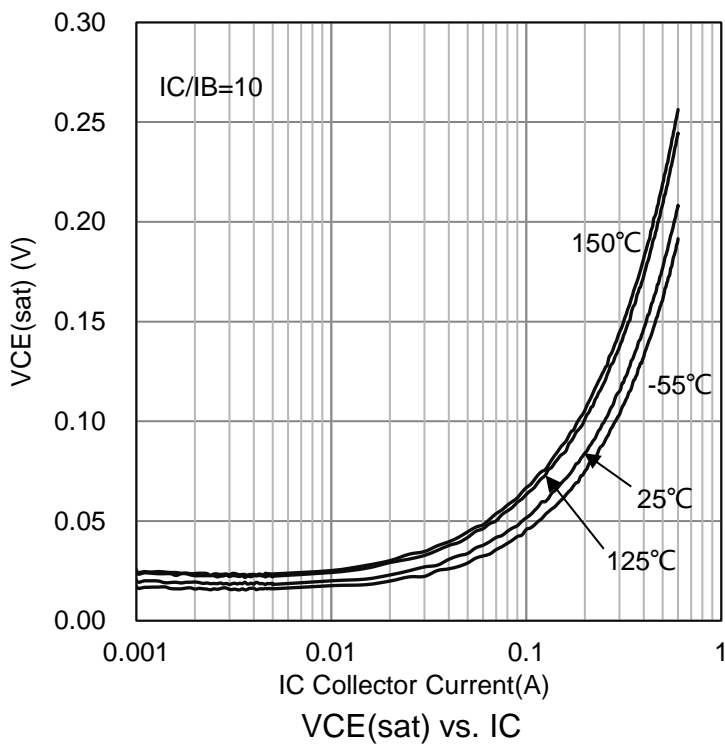
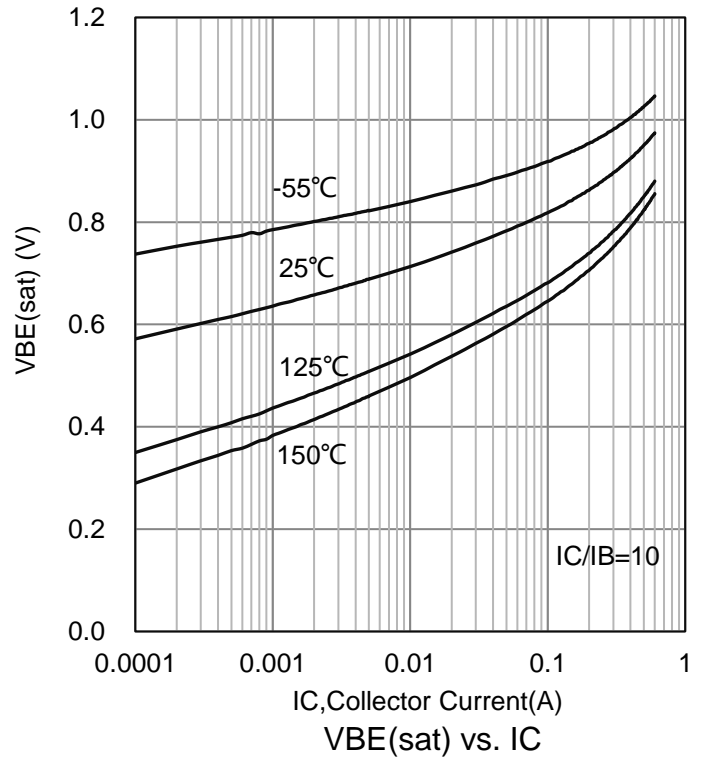
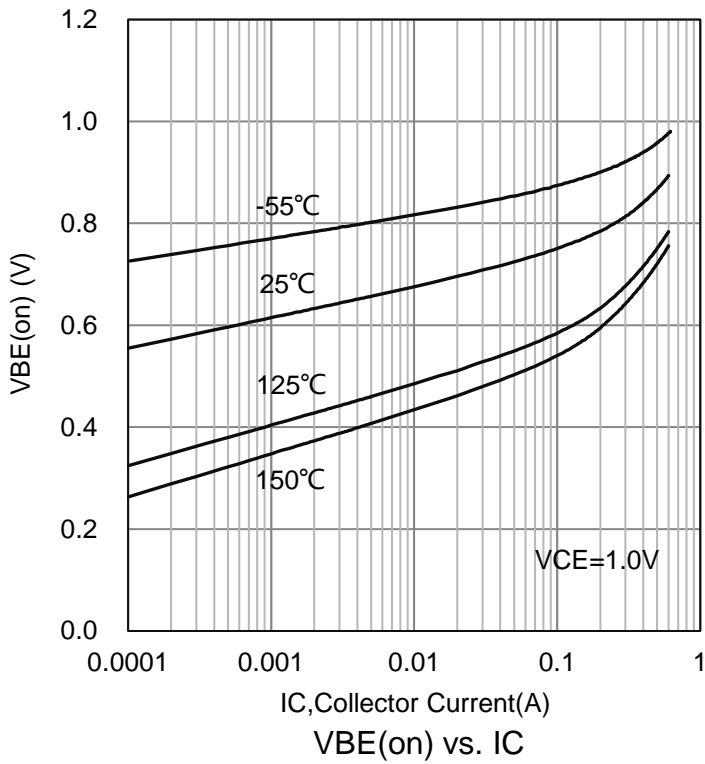

7. OUTLINE AND DIMENSIONS

Notes:

1. DIMENSIONING AND TOLERANCING PER ANSI Y14.5M, 1982.
2. CONTROLLING DIMENSION: MILLIMETERS.
3. MAXIMUM LEAD THICKNESS INCLUDES LEAD FINISH. MINIMUM LEAD THICKNESS IS THE MINIMUM THICKNESS OF BASE MATERIAL.
4. DIMENSIONS D AND E DO NOT INCLUDE MOLD FLASH, PROTRUSIONS OR GATE BURRS.

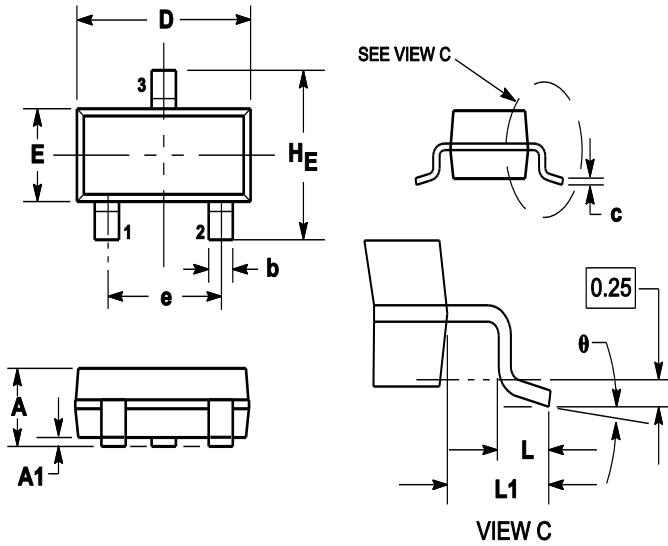

DIM	MILLIMETERS			INCHES		
	MIN	NOM	MAX	MIN	NOM	MAX
A	0.89	1	1.11	0.035	0.04	0.044
A1	0.01	0.06	0.1	0.001	0.002	0.004
b	0.37	0.44	0.5	0.015	0.018	0.02
c	0.09	0.13	0.18	0.003	0.005	0.007
D	2.80	2.9	3.04	0.11	0.114	0.12
E	1.20	1.3	1.4	0.047	0.051	0.055
e	1.78	1.9	2.04	0.07	0.075	0.081
L	0.10	0.2	0.3	0.004	0.008	0.012
L1	0.35	0.54	0.69	0.014	0.021	0.029
HE	2.10	2.4	2.64	0.083	0.094	0.104
θ	0°	---	10°	0°	---	10°

8. SOLDERING FOOTPRINT

